

The HV 2/4(6) high-voltage power supply

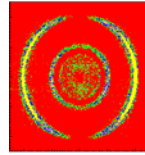

RoentDek
Handels GmbH
Supersonic Gas Jets
Detection Techniques
Data Acquisition Systems
Multifragment Imaging Systems

The **RoentDek** 2x4kV (or 6kV) Power Supply is especially designed for the use of biasing multi-channel-plate detectors or similar SEM devices, featuring low-ripple and regulated current limitation and protection. It is to be powered by a NIM crate or the **RoentDek** SPS2 mains adapter (**RoentDek** BIASET3). It is also possible to externally supply the operation voltage $\pm 24V$ DC (with low ripple as in NIM-crate standard) via the 9 pin socket on the rear panel, e.g. from the **SPS2(mini)**.

The switches on the side panel will set independently the respective channels to negative or positive output polarity, indicated by a LED on the front panel. If a channel of the power supply is switched on (indicated by a LED), and the “control” switch is set to upward position, the 10-turn potentiometers at the front panel can be used for manual voltage setting U_a (10 turns correspond to 4000V, resp. 6000V, with linear progression).

The voltages can also be ramped externally with an analog voltage 0 to +10 V DC (0 to 6V for the **HV2/6**) input to the Lemo00-sockets on the rear panel (e.g. from the **RoentDek** **USB-IO1**). For this the “control” switch is set to “DAC”. The A/B switch will set the display to channel A/B, the V/I switch will enable voltage or current reading of the respective channel. The accuracy of the reading is within a few volts and a few μA (typically 1 μA), respectively.

The maximum current delivered is 3mA (1mA for **HV2/6**), the maximum voltage is $\pm 4kV$ (6kV). Both can be restricted in 10% steps of the maximum.

If the trip protection switch is set to “enable kill” the voltage will be turned off in case of over-current or over-voltage, according to the settings of V_{max} and I_{max} . Otherwise the module will try to engage the voltage again after limiting the current for a while (and usually dropping the voltage), however it will trip again if the problem persists. It will under no circumstance deliver more voltage/current than pre-set. Optionally, the channels can be coupled so that both channels are switched off when any of the channels trip.

A TTL signal (“high”) on the “inhibit” input will also deactivate the voltage, like the event of an over-current, according to the position of the “enable kill” switch.

The red “error” LED will indicate the event of an over-current, over-voltage or “inhibit”.

The hardware ramp speed is 500V/sec max. (power switch on/off).

Further specifications:

Operation temperature:	0 ... +50°C
Storing temperature*	-20 ... +60°C
Ripple (peak-to-peak)	< 50mV
Stability	$\Delta U_a < 2 \times 10^{-4}$ or 5×10^{-5} of ΔU_c
Temperature coefficient	$< 1 \times 10^{-4}/^\circ C$

Note that the operation of **HV2/4(6)** requires an adequate pull-up preventer circuit like the **RoentDek** **HVT** only when operating two channels with same polarity and supplying resistive-coupled contacts such as the two sides of an MCP stack.



Figure: 2x4kV high-voltage power supply (front panel)

The Pseudo-floating power supply options PF+ and PF-:

For some applications it is beneficial to operate a detector in the *pseudo-floating* mode where the high voltage output of one **HV2/4** (or **HV2/6**) channel (A, from the upper SHV-socket on the rear panel) is set to a certain potential via the corresponding upper manual dial on the front panel (or remote control) and the other manual dial (or remote control) defines the output potential difference between the SHV output sockets on the rear panel. Depending on the selected output polarities for both channels the potential on the lower SHV-socket on the rear panel corresponds the arithmetic sum (version **PF+**) or difference (version **PF-**) of the set values A and B:

$$B' = B + A \quad \text{and} \quad A' = A \quad \text{(for PF+, same polarity)}$$

$$B' = B - A \quad \text{and} \quad A' = A \quad \text{with } B > A \quad \text{(for PF-, different polarities)}$$

with A' , B' defining the absolute values (in the mathematical sense) of the effective output voltages from the SHV sockets (with positive or negative polarity depending on the respective switch positions) and A, B defining the set values on the front panel dials or adjusted by the remote control levels.

It is to note, however, that B' can never exceed the maximum rating of the specific high voltage supply, e.g. is always $< 4\text{kV}$ for **HV2/4PF+** even if $(B + A)$ would mathematically yield a higher value. For the **PF-** version the minimum value of B' is 0, i.e. the polarity of the output cannot change if $(B - A)$ would mathematically yield a negative value.

This option allows keeping the potential difference between the high voltage outputs constant (corresponding to the B set value) while the potential of channel A is changed: if the setting A (and A' output) is increased by (for example) 100V, B' output will also be increased (or reduced) by 100V, as if operating with a floating power supply. Changes of setting on B will only affect voltage output B' .

However, it is to note that the high voltage outputs of the **HV2/4PF** are not floating, only the function of a floating power supply channel as simulated by special voltage control circuits inside the **HV2/4PF**. Therefore it is not possible to reverse the output polarity of B' by changing set values from $A < B$ to $A > B$.

The **PF+** version is designed for operation with both output channels on same polarity only while the **PF-** version is required when the same pseudo-floating functionality is needed at different polarities on the two output channels.

Examples for HV2/4PF+/-	pol. A	A set range and output	B set (diff.)	pol. B	output on lower SHV socket B' = B + A (PF+)
electron mode	+	0V to 1300V (front)	2700V	+	+2700V to +4000V (back)
pos. ion mode	-	1300V to 0V (back)	2700V	-	- 4000V to -2700V (front)
					B' = B - A (PF+)
alternate mode	-	2700V to 0V (front)	2700V	+	0V to +2700V (back)

Note that the also the pseudo-floating high voltage units may need an adequate pull-up preventer circuit like in **RoentDek HVT** when operating two channels at the same polarity supplying resistive-coupled contacts such as the two sides of an MCP stack.

The operation modes **PF+** or **PF-** are factory-fixed and cannot be changed

The **HV2/4PF+/-** units are only available as N24 versions and require $\pm 24\text{V}$ Volt DC power input from a NIM bin or via the **RoentDek SPS2(mini)** mains adapter.

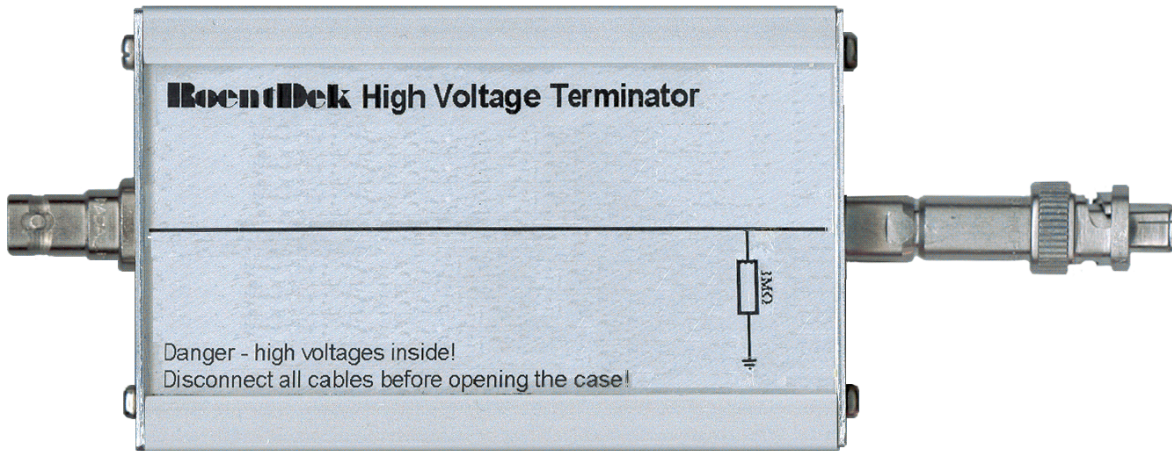

Figure: 2x4kV high-voltage power supply (front panel) as PF+ version

Passive add on circuits: HVT(+)

If a micro-channel plate stack (MCP) or similar device shall be biased with the same polarity on both sides (e.g. positive, for electron detection), most high voltage power supplies' control circuits cannot stabilize the lower bias setting: As soon as one supply is ramped to a high bias (e.g. on MCP back side), it will "pull away" the bias of the other MCP side in spite of a low-voltage setting on the dial. This is also the case for the **RoentDek** high voltage power supplies.

This pull-away effect is prevented simply by placing a well-selected parallel resistor to ground. This is easiest achieved by connecting the **RoentDek High Voltage Terminator** box **HVT** in-line behind the (lower) voltage output on the high voltage supply..



The **HVT** is specified for up to 1 kV operation voltage. For higher (low) voltage settings the **HVT4** version is available.

A special version of the **HVT** allows for stable operation of the **RoentDek** high voltage power supplies even at very low voltages ($\ll 100$ V) for which the direct output line may show non-linear features because it is not specified for.

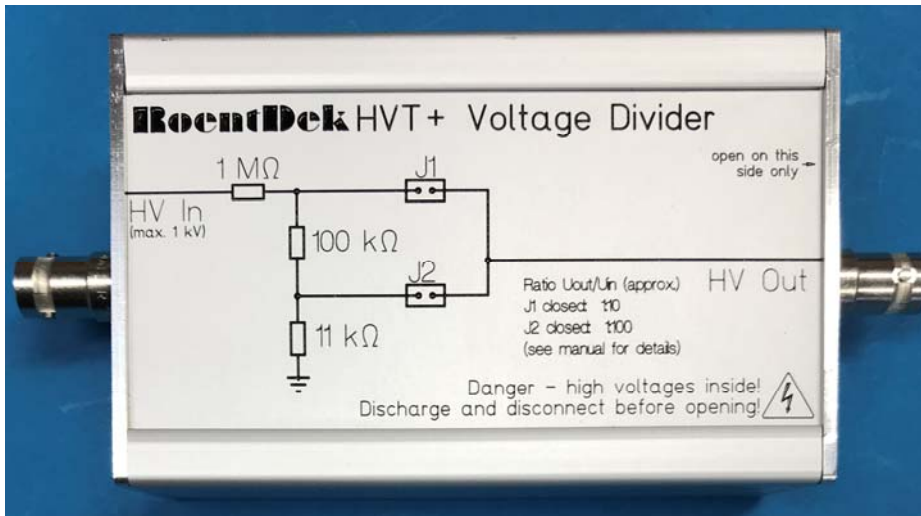

The **HVT+** voltage divider allows to downscale the effective voltage output by a factor of 10 or 100 (depending on jumper settings) so that very small voltages even below 1 V can be biased while the high voltage supply operates in its designated range of optimal stability.

Passive add-on circuits for **RoentDek** delay-line detectors: BA3 and HVZ

Especially in combination with **RoentDek** delay-line detectors two other types of passive-circuit boxes can supplement the high voltage units for effective biasing of an experimental setup, minimizing the need for active power supply channels.

The **BA3** battery unit features a floating voltage increase by about 40 V on an additional output socket. Its design application is the bias of a helical wire (twin) delay-line array only via a single active high voltage output, but it can also be used for example as a block voltage in absence of an active bias, i.e. for photo-cathodes. Several **BA3** units can be cascaded and combined with other devices.

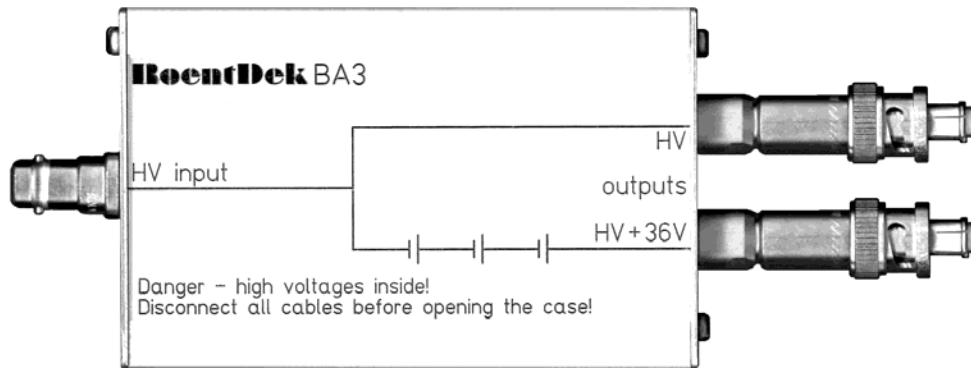

The **RoentDek HVZ** voltage distributing box generates intermediate potentials in steps of 28 V or 56 V ($\pm 10\%$) on three additional outputs (e.g. for all rear-side bias inputs of a **RoentDek** delay-line detector) if $> 1 \mu\text{A}$ of current is flowing by connecting a “drain” to the “Back” output and as soon as the voltage on the input is higher than the set total voltage gap of about 200 – 300 V. This and the specific voltages between some of the outputs are adjustable by jumpers.

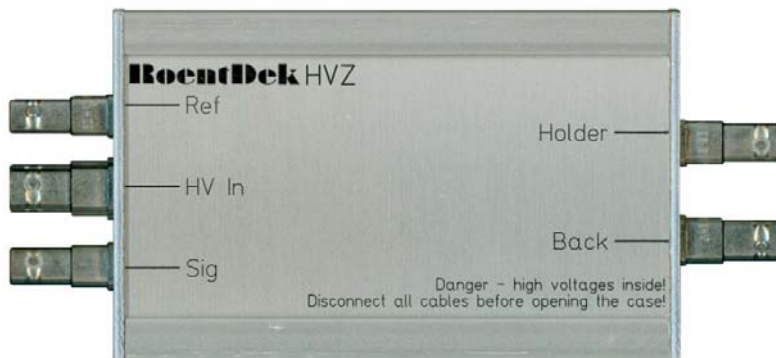

The **HVZ-T** version has only two such outputs and additionally contains the **HVT** circuit within the same box.

Being similar in function to a “classical” voltage divider box such as the **HVT(4)+**, voltage outputs of the **HVZ** always maintain the same voltage difference independent of the total voltage applied (as soon as HV_{in} is beyond 200 – 300 V of set total voltage gap).

RoentDek *BIASET* frame and *SPS2mini* mains adapter

To operate the **RoentDek** 2×4kV (or 6kV) high voltage units independent of NIM crates **RoentDek** offers the mains adapter *SPS2mini* and can supply a frame to host up to three high voltage units (*BIASET*)



SPS2mini mains adapter (100 – 250 V AC) to supply up to three high voltage units. Here, the *BIASET2* (two HV units with *SPSmini* and standard frame) is shown.

Not shown are included SHV cables, 24 V mains power transformer and cables to the HV units (mains power cord not included.)

The table top frame can be fixed in side-way rotated orientation to a 19" 3HU rack, optionally in upright position inside a 6HU rack (slightly modified frame).

RoentDek *USB-IO1* DA/AD controller

The voltage setting of the *HV2/4(6)* units can be operated via the **RoentDek** *USB-IO1* DA/AD controller. If the control switches on a *HV2/4(6)* unit is set to "DAC" its high voltage output is proportional to the voltage input on the corresponding input socket on the rear panel. A *USB-IO1* can provide two individual voltage outputs up to 10 V for this purpose, controlled by software via USB connection to a PC. Shown below are front and rear panels of the *USB-IO1* device with USB-port for the PC-connection and the two LEMO analogue *out2* and *out1* output sockets, suitable for remote-controlling *HV2/4(6)* units.

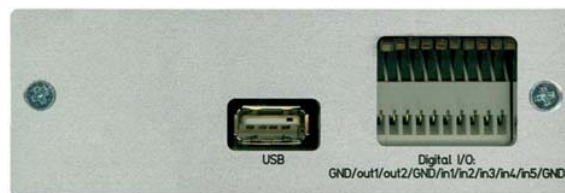

The standalone case of the *USB-IO1* has similar dimensions as the *SPSmini* and is powered via USB cable.